

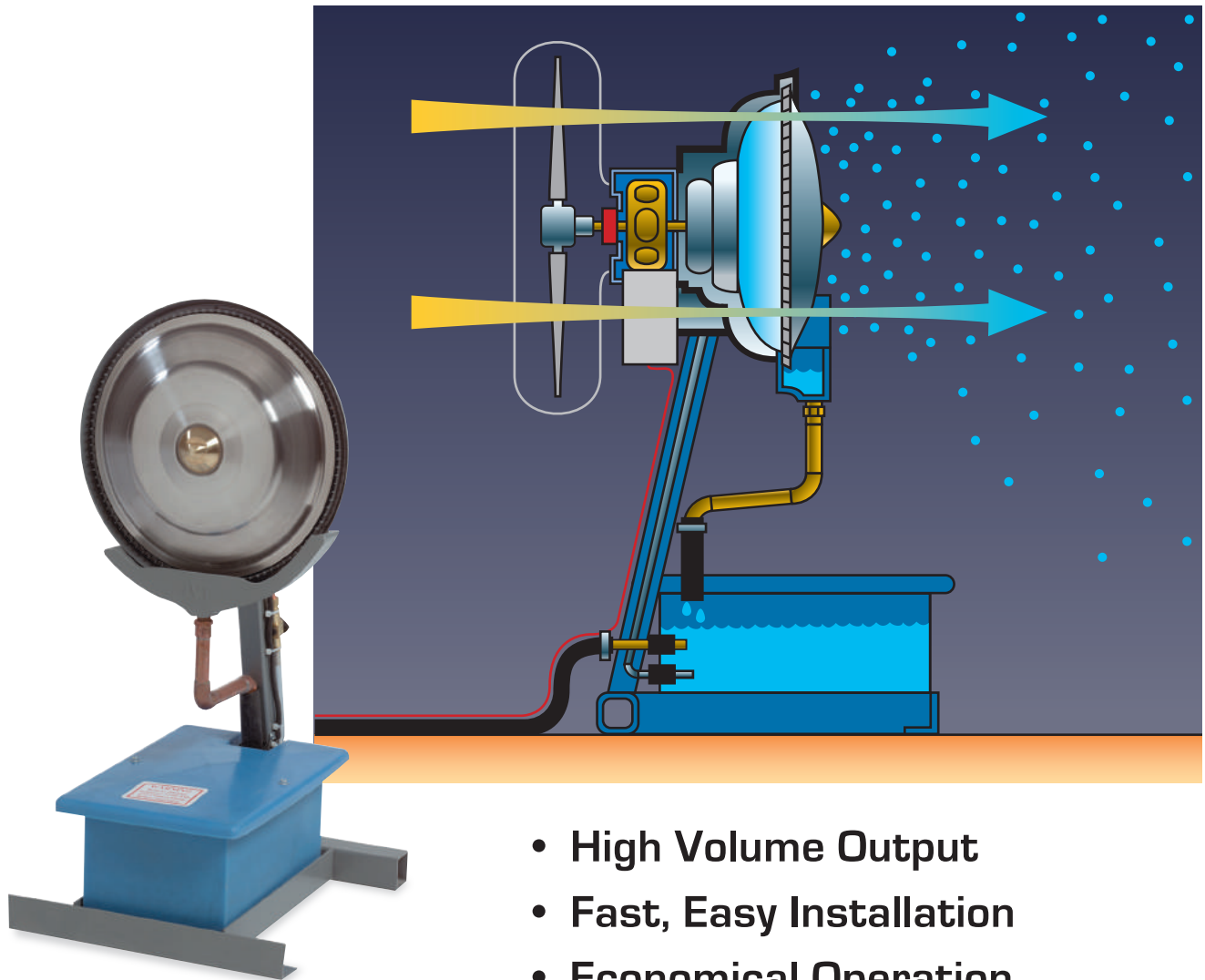

CENTRIFUGAL HUMIDIFIER

30-Series



- High Volume Output
- Fast, Easy Installation
- Economical Operation

CENTRIFUGAL HUMIDIFIER

30-Series

A commercial-grade humidifier for use in applications requiring a higher volume of dependable humidification.

FEATURES AND BENEFITS

- HIGHER CAPACITY**
 Capable of producing 30 gallons of atomized water per hour.
- ECONOMICAL OPERATION**
 The efficient 1/2 H.P. motor uses very little electricity.
- RUGGED CONSTRUCTION**
 Durable, lightweight polyethylene water reservoir provides a long service life with minimal maintenance.
- VERSATILE**
 Available in eight models, including ceiling-mounted and portable floor-standing units with wheels.
- SIMPLE INSTALLATION**
 Many models require only a standard power connection and water source.
- VARIETY OF APPLICATIONS**
 Provides efficient humidification for vegetable growing and storage, wood products production, textile manufacturing, printing, paper storage and more.

GENERAL SPECIFICATIONS

SUMP PUMP:	115 Volt; 1-phase; 50/60 cycle with float-operated make-up valve in polyethylene reservoir
MOTOR:	1-phase or 3-phase; 1/2 H.P. 50/60 Hz
HUMIDIFYING CAPACITY:	Up to 30 gallons per hour
FAN:	Available with or without 2-blade fan & fan guard

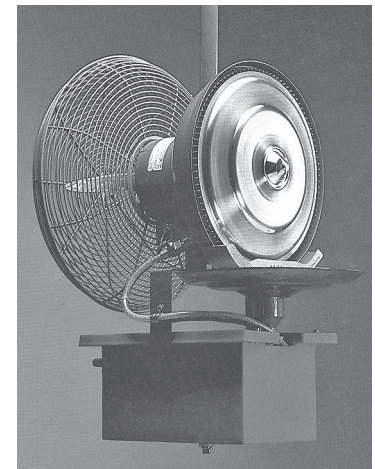

Pictured above is IVI's Centrifugal Humidifier ceiling mounted with 2-blade fan and fan guard option.



723 E. Karcher Road, Nampa, Idaho 83687 • ph: 208-463-6305 • fax: 208-463-6307 • website: ivi-air.com

Branches: Heyburn, ID, ph: 208-678-7788 • Idaho Falls, ID, ph: 208-529-1777 • Klamath Falls, OR, ph: 541-591-0892 • Pasco, WA, ph: 509-545-9751
 Monte Vista, CO, ph: 719-588-2485 • Fargo, ND, ph: 701-353-0100 • Georgia (SE USA), ph: 404-432-8977

250-0917